

仅供参考

REV.	REVISION RECORD	DATE
A0	新图面发行	2017. 06. 16

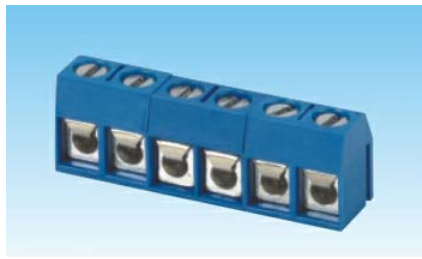

产品型号	MODEL	ST301R	
材质&电镀	MATERIAL&PLATING		
螺丝	Screw	M2.5, 钢, 镀锌	steel, Zinc Plated
弹片	Reed	磷青铜镀镍或不锈钢	Phosphor Bronze, Ni plated or stainless steel
焊针	Pin header	黄铜, 镀锡	Brass, Tin plated
塑件	Housing	PBT, UL94V-0	
电气性能	ELECTRICAL	UL	IEC
额定电压	Rated voltage	300V	250V
额定电流	Rated current	12A	17.5A
接触电阻	Contact resistance	20mΩ	
绝缘电阻	Insulation resistance	500MΩ/1000V	
耐电压	Withstanding voltage	AC2000V/1min	
使用线径	Wire range	22-14AWG 2.5mm ²	
机械性能	MECHANICAL		
温度范围	Temp. range	-30°C ~ +120°C	
瞬时温度	Max. soldering	+250°C, 5sec	
扭矩	Torque	0.4N.m	3.5Lb. in
剥线长度	Strip length	4.5-5mm	

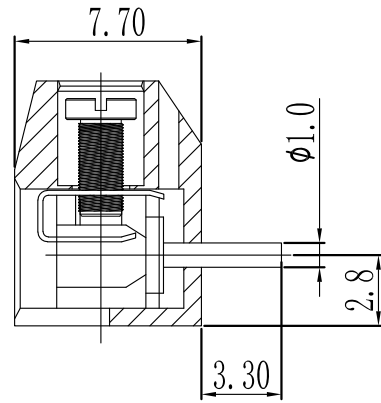
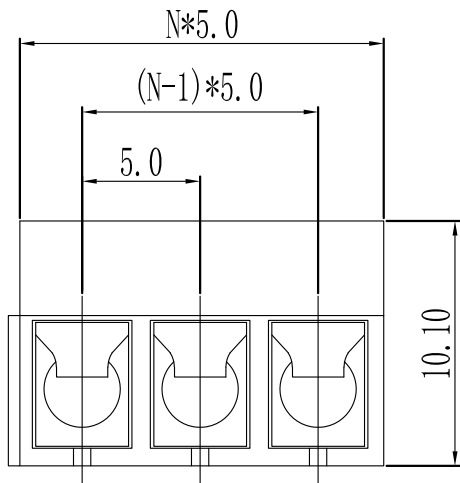

N=Number of Contacts

	GENERAL TOLERANCES		SCALE: 1:1	NAME	DATE	深圳市思拓展电子有限公司 SHENZHEN SINTOP ELECTRONICS CO., LTD 公司网址: www.szsituo.cn 公司电话: 0755-23765350 邮 箱: 2850175982@qq.com 公司传真: 0755-23765341	PART. NO: ST-TB-0007	
	LINEAR	ANGLES					APPROVED	
	0.0±0.30	X° REF±6°	DESIGNER			TITLE:	Pitch 5.00mm	
UNIT: MM	0.00±0.20	X° ±3°	DRAWN	肖坤权	2017. 06. 16	Euro Terminal Blocks		REV: A0
SIZE: A4	0.000±0.10	X° X'±2°						SHEET: 1/1