

仅供参考

REV.	REVISION RECORD	DATE
A0	新图面发行	2017.06.16

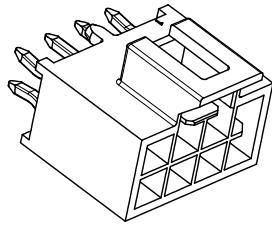

Specifications:  
 Voltage Rating : 250V AC/DC  
 Current Rating : 3A AC,DC  
 Withstand Voltage : 1500V AC/minute  
 Contact Resistance : 40mΩ(MAX.)  
 Insulation Resistance : 1000MΩ(MIN.)  
 Temperature Range : -40°C~+105°C

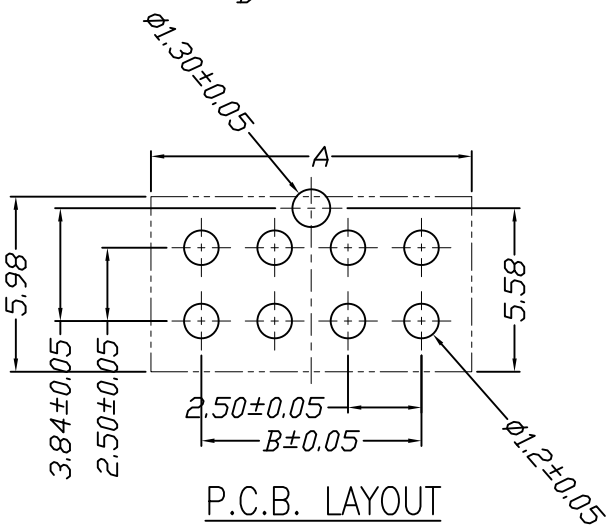
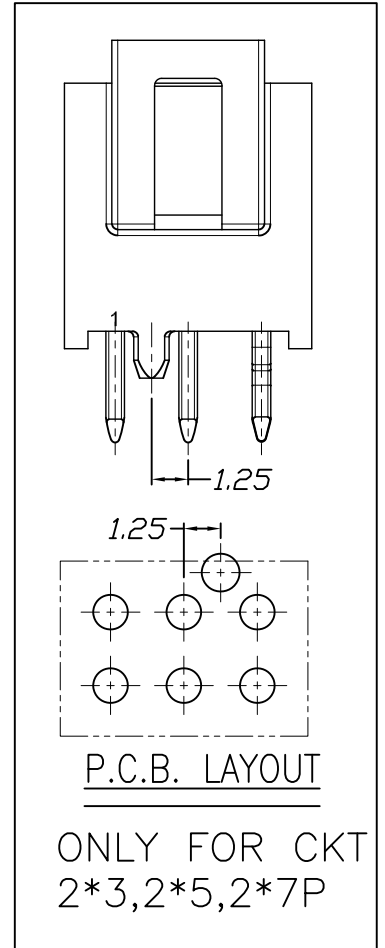
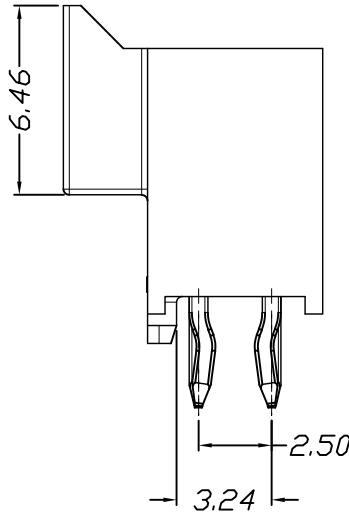
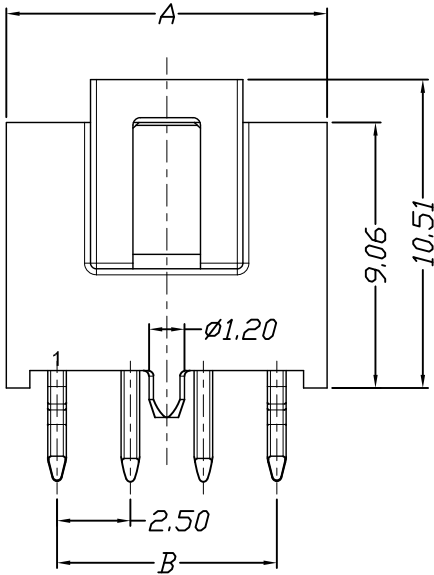
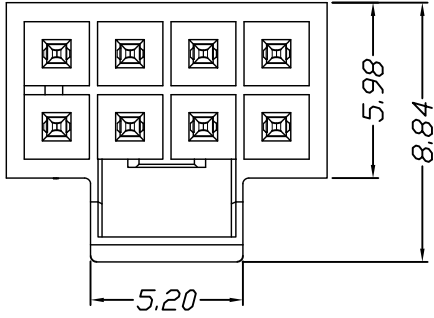

Poles	Dimensions	
	A	B
2*2P	5.94	2.50
2*3P	8.44	5.00
2*4P	10.94	7.50
2*5P	13.44	10.00
2*6P	15.94	12.50
2*7P	18.44	15.00
2*8P	20.94	17.50

Material	Color	PIN Material
LCP	Black	Brass

	GENERAL TOLERANCES		SCALE: 1:1	NAME	DATE	深圳市思拓展电子有限公司 SHENZHEN SINOTOP ELECTRONICS CO., LTD 公司网址: www.szstuo.cn 公司电话: 0755-23765350 邮箱: 2850175982@qq.com 公司传真: 0755-23765341	PART NO: STP42508W00-2XNPX-A1-XX
	LINEAR	ANGLES					
UNIT: MM	0.00±0.25	X° ±3°	DESIGNER			TITLE:	DWG. NO:
SIZE: A4	0.000±0.15	X° X'±2°	DRAWN	肖坤权	2017.06.16	2.50mm Pitch 180° Wafer DIP Type	REV: A0 SHEET: 1/1