

仅供参考

REV.	REVISION RECORD	DATE
A0	新图面发行	2017.06.16

Specifications:
 Voltage Rating : 250V AC/DC
 Current Rating : 5A AC,DC
 Withstand Voltage : 1500V AC/minute
 Contact Resistance : 40mΩ(MAX.)
 Insulation Resistance : 1000MΩ(MIN.)
 Temperature Range : -55°C~+105°C

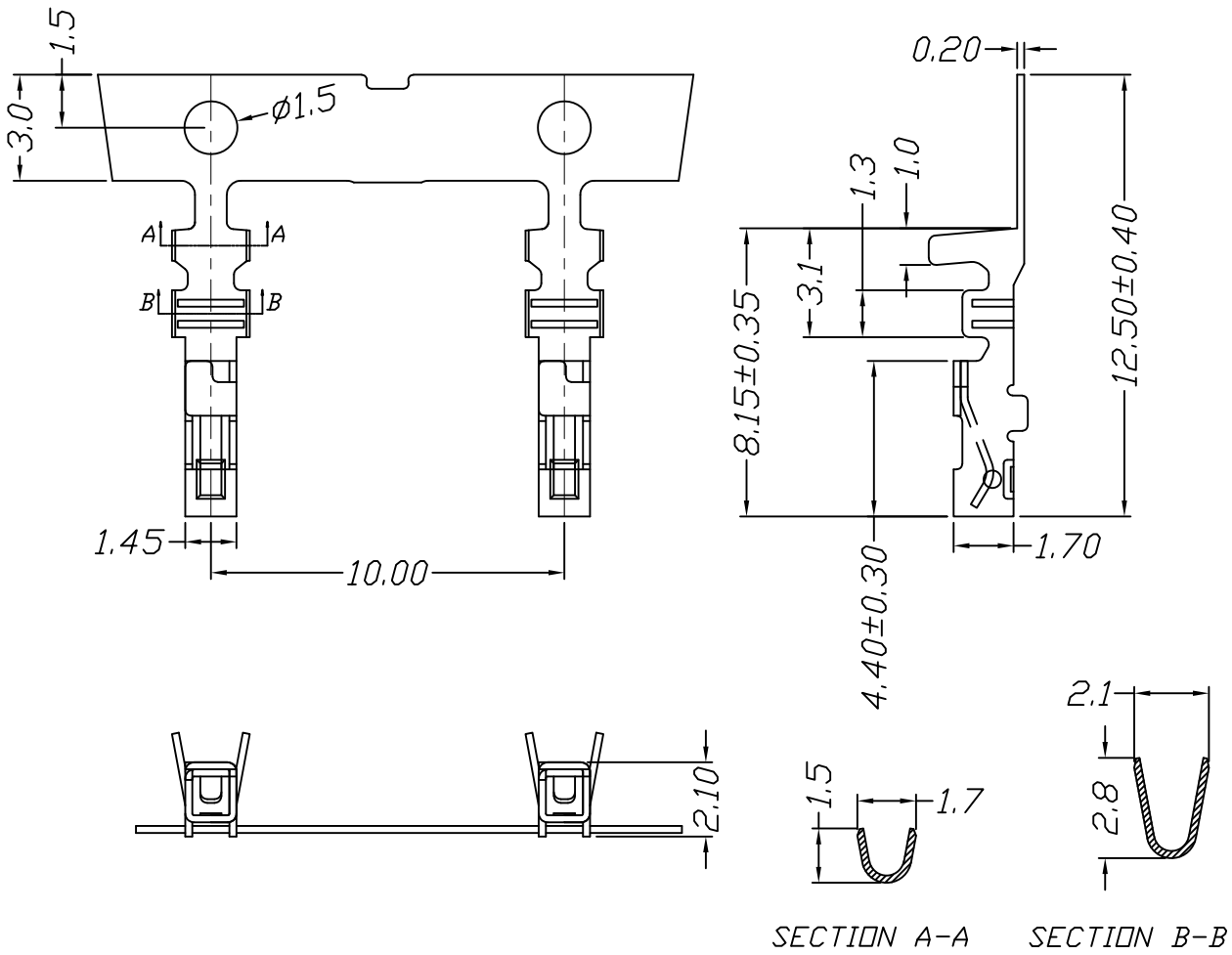

Wire Range	Insulation O. D.	Material	Finish	Qty/Reel
AWG #18~#22	1.00mm(max)	Phosphor bronze	Au or Sn	

	GENERAL TOLERANCES		SCALE: 1:1	NAME	DATE	深圳市思拓展电子有限公司 SHENZHEN SINOTOP ELECTRONICS CO., LTD 公司网址: www.szstuo.cn 公司电话: 0755-23765350 邮箱: 2850175982@qq.com 公司传真: 0755-23765341	PART. NO: STP42501T0P-XX-X
	LINEAR	ANGLES	APPROVED				DWG. NO:
	0.0±0.35	X° REF±6°	DESIGNER				
	UNIT: MM	0.00±0.25	X° ±3°	DRAWN	肖坤权		2017.06.16
SIZE: A4	0.000±0.15	X° X'±2°	TITLE: 2.50mm PITCH Crimp Terminal				