

仅供参考

REV.	REVISION RECORD	DATE
A0	新图面发行	2017. 06. 16

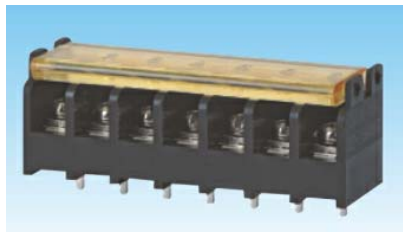

产品型号	MODEL	HB-850M
材质&电镀	MATERIAL&PLATING	
螺丝	Screw	M3.5, 钢, 镀镍 Steel, Nickel Plated
端子	Terminal	黄铜, 0.7t 镀锡 Brass, Tin Plated
塑件	Housing	PA66, UL94V-0
电气性能	ELECTRICAL	
额定电压	Rated voltage	300V
额定电流	Rated current	20A
绝缘电阻	Insulation resistance	500MΩ/DC500V
耐电压	Withstanding voltage	AC2000V/1min
使用线径	Wire range	22-14AWG 2.5mm ²
机械性能	MECHANICAL	
温度范围	Temp. range	-40℃~+105℃
扭矩	Torque	0.8N.m 7.02Lb.in

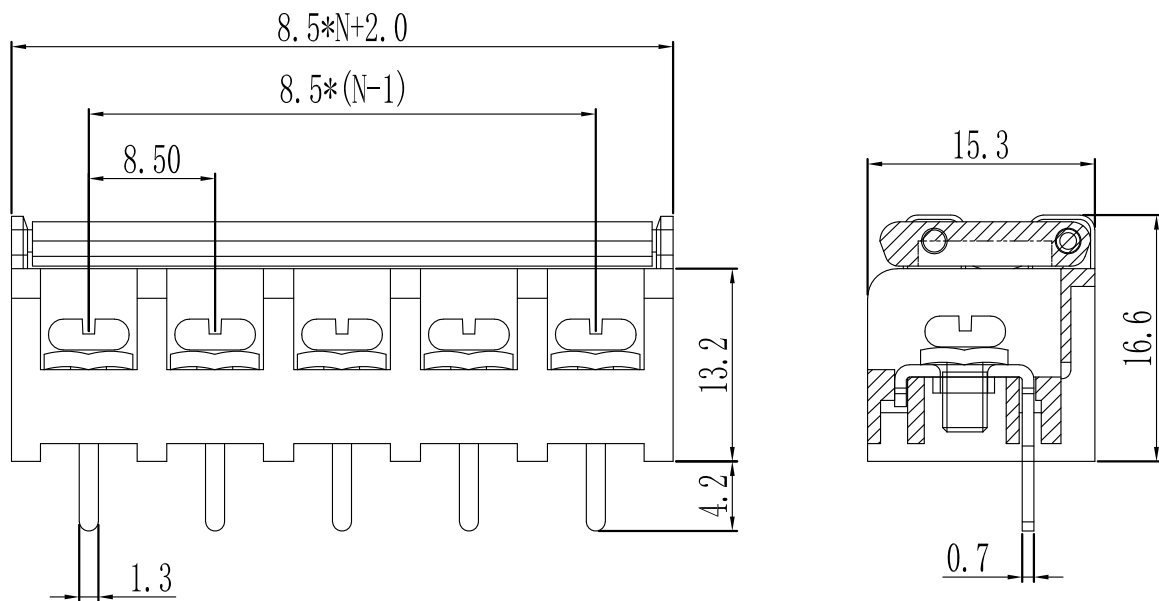

N=Number of Contacts

	GENERAL TOLERANCES		SCALE: 1:1	NAME	DATE	深圳市思拓展电子有限公司 SHENZHEN SINTOP ELECTRONICS CO., LTD 公司网址: www.szsituo.cn 公司电话: 0755-23765350 邮 箱: 2850175982@qq.com 公司传真: 0755-23765341	PART. NO: ST-TB-0254
	LINEAR	ANGLES	APPROVED				DWG. NO:
UNIT: MM	0.0±0.30	X° REF±6°	DESIGNER			TITLE: Pitch8.50mm American/Japanese Terminal Blocks	REV: A0
SIZE: A4	0.000±0.10	X° X'±2°	DRAWN	肖坤权	2017.06.16		SHEET: 1/1