

仅供参考

REV.	REVISION RECORD	DATE
A0	新图面发行	2017. 06. 16

Specifications:
 Contact resistance: $\leq 20m\Omega$
 Insulation resistance: $\geq 1000M\Omega$
 Rated voltage: 125V AC DC
 Rated current: 3.0A AC DC
 Withstand Voltage: 1000V AC/minute
 Temperature Range: $-40^{\circ}C \sim +105^{\circ}C$
 Housing: NYLON66 UL94V-0 NATURAL

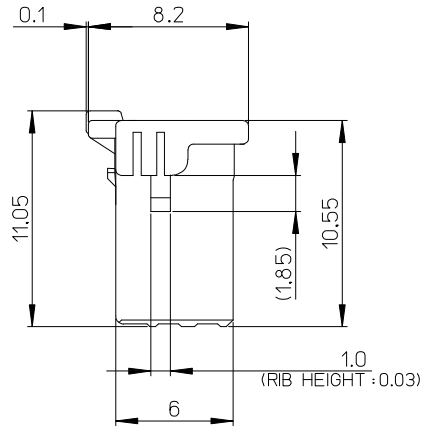
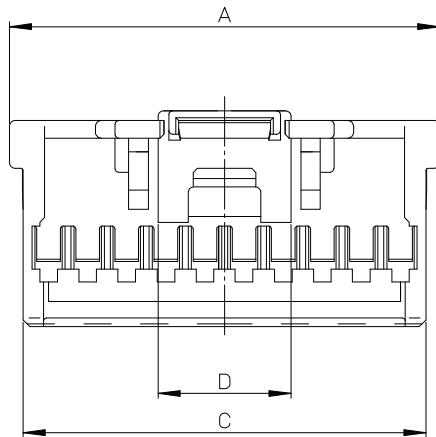
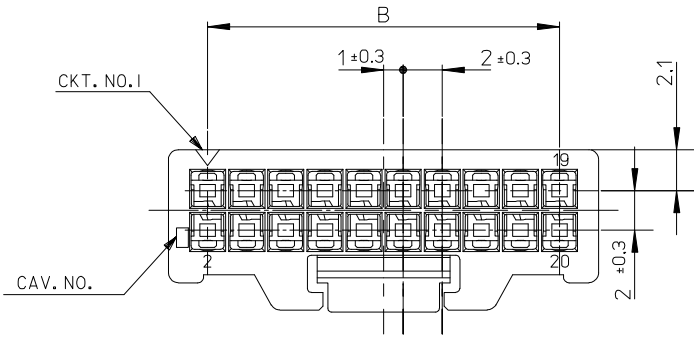

6.8	40.6	38	42	40
6.8	38.6	36	40	38
6.8	36.6	34	38	36
6.8	34.6	32	36	34
6.8	32.6	30	34	32
6.8	30.6	28	32	30
6.8	28.6	26	30	28
6.8	26.6	24	28	26
6.8	24.6	22	26	24
6.8	22.6	20	24	22
6.8	20.6	18	22	20
6.8	18.6	16	20	18
6.8	16.6	14	18	16
6.8	14.6	12	16	14
6.8	12.6	10	14	12
5.1	10.6	8	12	10
D	C	B	A	CKT.

	GENERAL TOLERANCES		SCALE: 1:1	NAME	DATE	深圳市思拓展电子有限公司 SHENZHEN SINOTOP ELECTRONICS CO., LTD 公司网址: www.szstuo.cn 公司电话: 0755-23765350 邮 箱: 2850175982@qq.com 公司传真: 0755-23765341	PART. NO: ST-WF-200-005Y	
	LINEAR	ANGLES	APPROVED				DWG. NO:	
	0.0 ± 0.30	X° REF ± 6°	DESIGNER				TITLE: 2.00mm PITCH HOUSING	REV: A0 SHEET: 1/1
	UNIT: MM	0.00 ± 0.20	X° ± 3°	DRAWN	肖坤权		2017. 06. 16	
SIZE: A4	0.000 ± 0.10	X° X' ± 2°						