

仅供参考

卷装+盖

REV.	REVISION RECORD	DATE
A0	新图面发行	2017.06.16

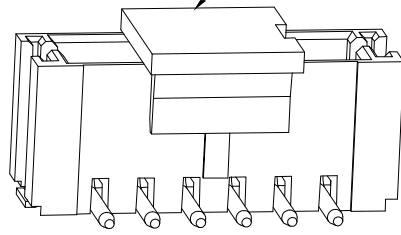

主要技术参数 Main Specifications

线数 (Poles): 02 to 16
 接触电阻 (Contact resistance): $\leq 20m\Omega$
 绝缘电阻 (Insulation resistance): $\geq 500M\Omega$
 额定电压 (Rated voltage): 125V AC DC
 额定电流 (Rated current): 1.0A AC DC
 耐电压 (Withstand Voltage): 500V AC/minute
 温度范围 (Temperature Range): $-25^{\circ}C \sim +105^{\circ}C$

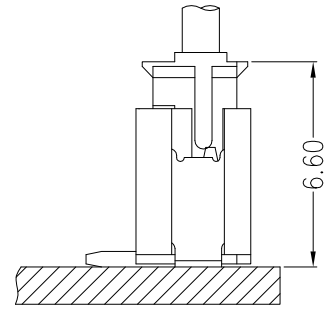
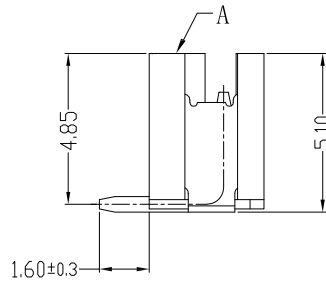
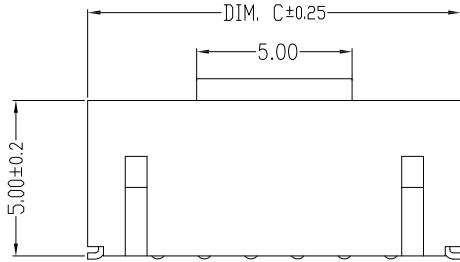

Assembly Layout

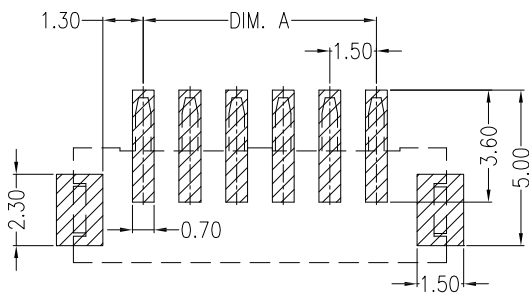
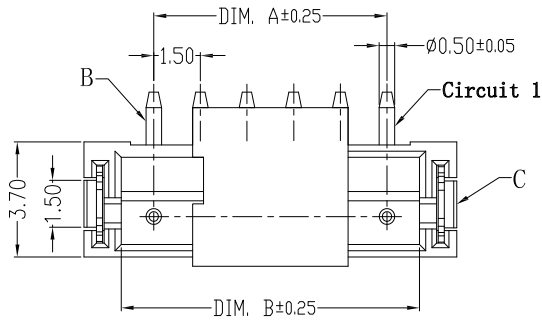

SUGGESTED PCB LAYOUT

Circuits	Dimensions (mm)		
	DIM. A	DIM. B	DIM. C
02	1.50	3.60	6.00
03	3.00	5.10	7.50
04	4.50	6.60	9.00
05	6.00	8.10	10.50
06	7.50	9.60	12.00
07	9.00	11.10	13.50
08	10.50	12.60	15.00
09	12.00	14.10	16.50
10	13.50	15.60	18.00
11	15.00	17.10	19.50
12	16.50	18.60	21.00
13	18.00	20.10	22.50
14	19.50	21.60	24.00
15	21.00	23.10	25.50
16	22.50	24.60	27.00

C	SOLDER TAB	2 PCS	PhosphorBronze	Sn-plated/Au
B	CONTACT	n PCS	Brass	Sn-plated/Au
A	PEDESTAL	1 PCS	LCP/PA9T	UL 94V-0, COLOR:BEIGE
ITEM	COMPONENT	Q'TY	MATERIAL	FINISH

	GENERAL TOLERANCES		SCALE: 1:1	NAME	DATE	深圳市思拓展电子有限公司 SHENZHEN SINOTOP ELECTRONICS CO., LTD 公司地址: www.szstuo.cn 公司电话: 0755-23765350 邮箱: 2850175982@qq.com 公司传真: 0755-23765341	PART. NO:	
	LINEAR	ANGLES	APPROVED				ST-WF-150-001AWV	
	0.0 ± 0.30	X° REF ± 6°	DESIGNER				DWG. NO:	
	UNIT: MM	0.00 ± 0.20	X° ± 3°	DRAWN	肖坤权		2017.06.16	REV: A0
SIZE: A4	0.000 ± 0.10	X° X' ± 2°				TITLE: 1.50mm PITCH 180° WAFER SMT TYPE		