

仅供参考

REV.	REVISION RECORD	DATE
A0	新图面发行	2017.06.16

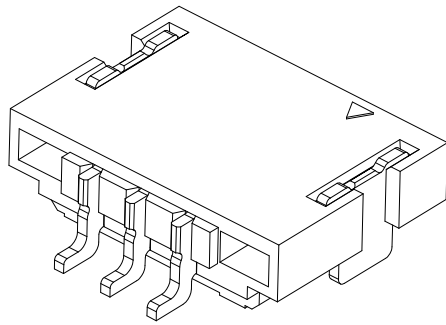

Specifications:

Contact resistance: $\leq 20m\Omega$
 Insulation resistance: $\geq 100M\Omega$
 Rated voltage: 50V AC DC
 Rated current: 1.0A AC DC
 Withstand Voltage: 500V AC/minute
 Temperature Range: $-25^{\circ}C \sim +85^{\circ}C$
 Housing: PA6T UL94V-0, Natural
 Contacts: Phosphor bronze/Matte Sn
 Solder Tabs: Phosphor bronze/Matte Sn

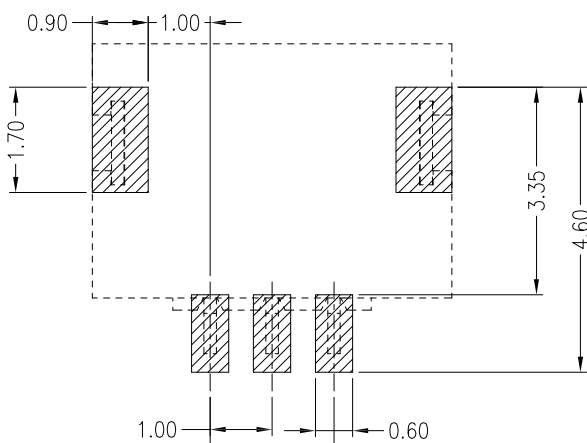
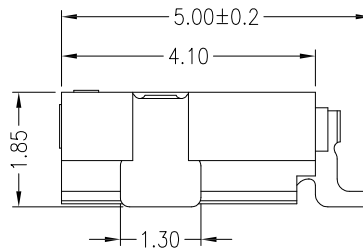
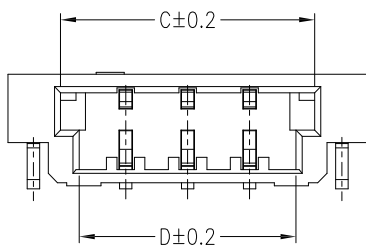
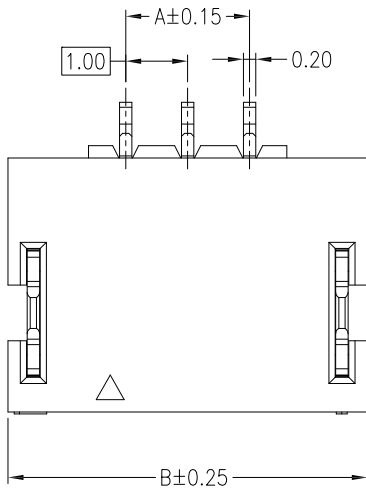

PCB LAYOUT

Circuits	Dimensions (mm)				Circuits	Dimensions (mm)			
	A	B	C	D		A	B	C	D
02	1.00	4.80	3.10	2.50	17	16.00	19.80	18.10	17.50
03	2.00	5.80	4.10	3.50	18	17.00	20.80	19.10	18.50
04	3.00	6.80	5.10	4.50	19	18.00	21.80	20.10	19.50
05	4.00	7.80	6.10	5.50	20	19.00	22.80	21.10	20.50
06	5.00	8.80	7.10	6.50	21	20.00	23.80	22.10	21.50
07	6.00	9.80	8.10	7.50	22	21.00	24.80	23.10	22.50
08	7.00	10.80	9.10	8.50	23	22.00	25.80	24.10	23.50
09	8.00	11.80	10.10	9.50	24	23.00	26.80	25.10	24.50
10	9.00	12.80	11.10	10.50	25	24.00	27.80	26.10	25.50
11	10.00	13.80	12.10	11.50	26	25.00	28.80	27.10	26.50
12	11.00	14.80	13.10	12.50	27	26.00	29.80	28.10	27.50
13	12.00	15.80	14.10	13.50	28	27.00	30.80	29.10	28.50
14	13.00	16.80	15.10	14.50	29	28.00	31.80	30.10	29.50
15	14.00	17.80	16.10	15.50	30	29.00	32.80	31.10	30.50
16	15.00	18.80	17.10	16.50					

	GENERAL TOLERANCES		SCALE: 1:1	NAME	DATE	深圳市思拓展电子有限公司 SHENZHEN SINOTOP ELECTRONICS CO., LTD 公司网址: www.szstuo.cn 公司电话: 0755-23765350 邮箱: 2850175982@qq.com 公司传真: 0755-23765341	PART. NO:	
	LINEAR	ANGLES					ST-WF-100-009AWR	
UNIT: MM	0.00±0.20	X° REF±6°	APPROVED				DWG. NO:	
SIZE: A4	0.000±0.10	X° X'±2°	DESIGNER				REV: A0 SHEET: 1/1	
			DRAWN	肖坤权	2017.06.16	TITLE:		
						1.0mmPITCH 90° WAFER SMT TYPE		